

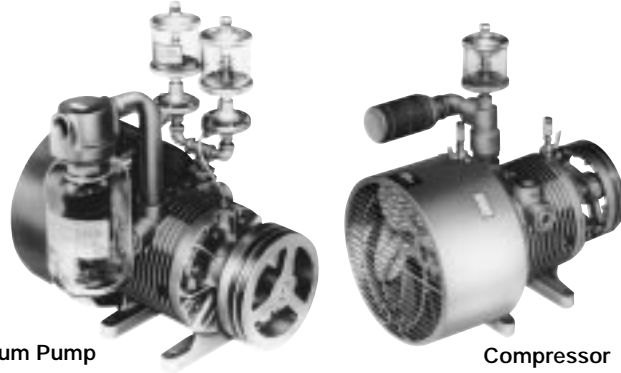

Separate Drive Rotary Vane

35.0 cfm at 1350 rpm, 47.5 cfm at 1725 rpm



Vacuum Pump

Compressor

Product Dimensions (mm, inches)

Dimensions are for reference only.

Vacuum Pump

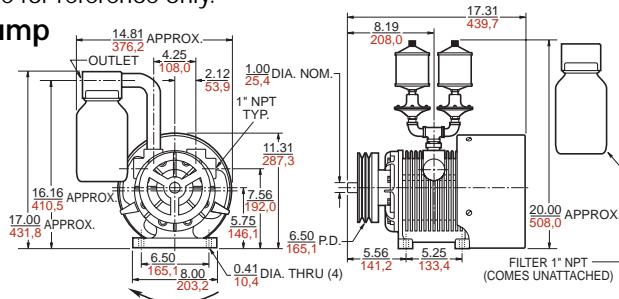

Compressor

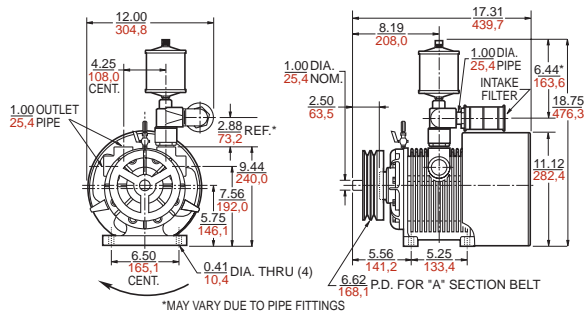

*MAY VARY DUE TO PIPE FITTINGS

Lubricated 4565 Series

MODEL 4565 SERIES

25" HG MAX. VAC., 47.5 CFM OPEN FLOW

15 PSI MAX. PRESSURE

PRODUCT FEATURES

- Lubricated operation
- Pulley driven (multiple speeds available)
- Rugged construction/low maintenance
- Essentially pulse-free service

INCLUDES

- Oil reservoir AA960A (2) on vacuum pump
- 6.5" P.D. pulley AC376B for "A" section belts
- Filter/muffler AD560 (2) on vacuum pump
- Filter AD750 (Compressor)
- Fan AD721
- Vacuum-actuated lubricator V40C (2)
- Pressure lubricator AD730

RECOMMENDED ACCESSORIES

- Base AB322C
- Vacuum relief valve AA308
- Pressure relief valve AA307
- Vacuum gauge AA640
- Pressure gauge AA644B
- Oil AD220
- Belt guard AB331B-1
- Repair kit K242 (Vacuum Pump)
- Repair kit K243 (Compressor)

Product Specifications Note: "P" models are pressure, "V" models are vacuum.

Model Number	Motor	Base	Belt Guard	RPM	HP	kW	Net Wt.	
							lbs.	kg
4565-P3	—	—	—	1725	5	3,7	103	46,4
4565-V6*/4565-V6A	—	—	—	1725	3	2,2	105	47,3
4565-V15D	—	•	•	1350	3	2,2	127	57,2
4565-V15D-T338	230/460-60-3	•	•	1350	3	2,2	187	84,2
4565-V15E	—	•	•	1725	3	2,2	127	57,2
4565-V15E-T338	230/460-60-3	•	•	1725	3	2,2	187	84,2

*Model 4565-V6 is the stock version and comes with plumbing unattached.

Product Performance (Metric, U.S.)

