



R7 SERIES

MODELS R7100A-3, R7100B-1

MAX. PRESSURE – 125" H₂O (60 Hz), 115" H₂O (50 Hz)

MAX. VACUUM – 110" H₂O (60 Hz), 90" H₂O (50 Hz)

MAX. AIR FLOW – 420 CFM (60 Hz), 350 CFM (50 Hz)

PRODUCT FEATURES

- Rugged construction, low maintenance
- Oilless operation
- UL and CSA approved TEFC motors with permanently sealed ball bearings
- IP54 rated enclosure on motors
- Aluminum impeller; cast iron cover and housing
- Can be mounted in any plane
- Inlet and outlet have internal muffling

RECOMMENDED ACCESSORIES

- Pressure gauge AE133A
- Inlet filter AJ126G (pressure)
- Vacuum gauge AE134
- Vacuum gauge for monitoring inlet filter restriction AJ497
- Pressure/vacuum relief valve AG258
- Silencer for vacuum relief valve AJ121D
- Inline filter AJ151H (vacuum)
- External muffler for additional silencing AJ121G
- Liquid separator RMS400 (vacuum)
- Foam replacement kit K827

Product Dimensions (in. mm)

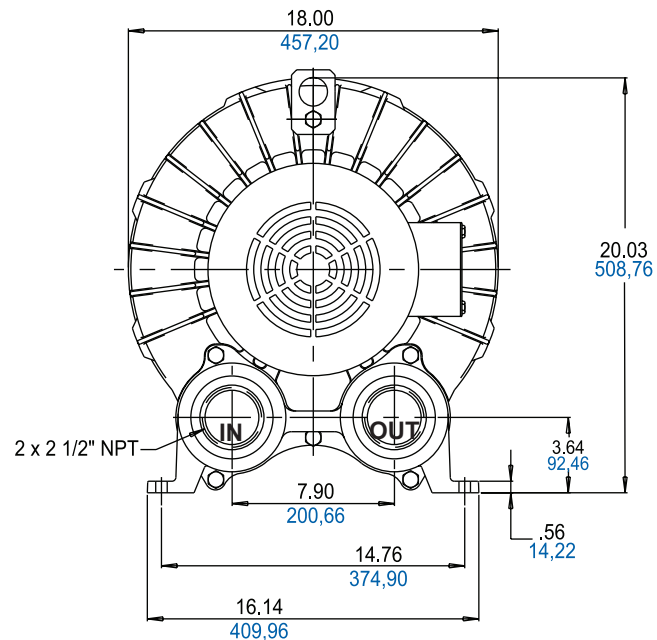
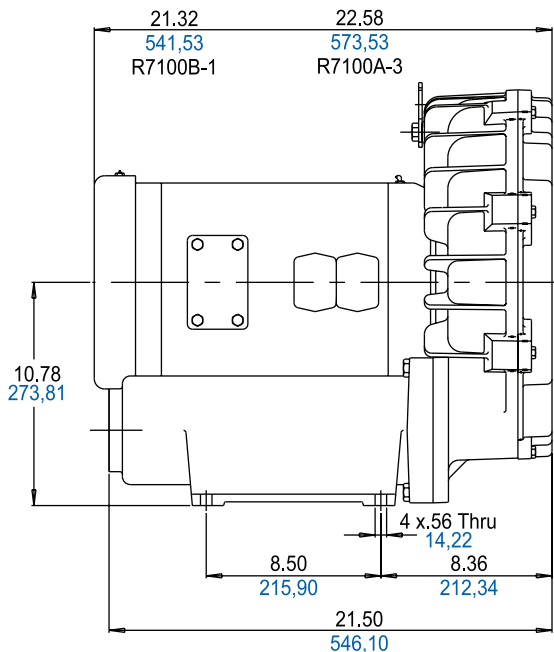



Product Specifications

MODEL NUMBER		R7100A-3	R7100B-1
Motor Enclosure		TEFC	TEFC
HP/kW	60 Hz	10/7,5	10/7,5
	50 Hz	8/6	-
Voltage	60 Hz	208-230/460-3	575-3
	50 Hz	190-220/380-440-3	-
Amps	60 Hz	35-29.5/15	9.6
	50 Hz	27-23/13.5-12.3	-
Starting Amps	60 Hz	120 @ 460V	84 @ 575V
	50 Hz	143 @ 380V	-
Insulation Class		F	F
Recommended NEMA Starter Size		2/1	1
Net Weight (lbs/kg)		324/147	290/131

Product Performance

